

# Dorgard Series

## Technical specification sheet

### Dorgard 1328-A01 (acoustic fire door retainer)

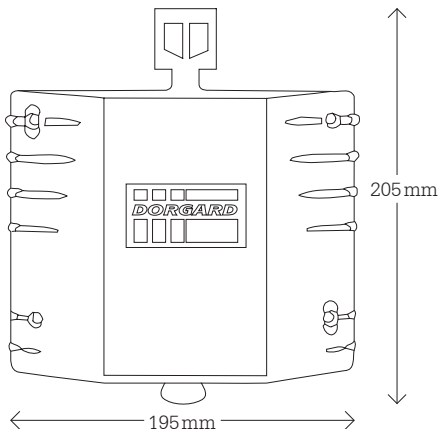

#### Dimensions and weight

- Overall height: 205 mm
- Main casing height: 150 mm
- Width: 195 mm
- Depth: 45 mm
- Packed kit weight: 950 g
- Product only (including batteries): 700 g

#### Material and operating specifications

- Casing: ABS
- Power: 2 x 1.5v C size alkaline batteries (do not use rechargeable batteries)
- Expected battery life: 12 months (may be less in noisy environments)
- Trigger: 2.4KHz continuous sound above 65 decibels(A)

#### Dorgard 1328-A01 approvals and standards

- BS EN 1155: 1997 building hardware. Electrically powered hold-open devices for swing doors. (Manufacturer's classification number 357113.)
- BS EN 61000-6-1:2001 electro-magnetic compatibility. Generic emission standard. Residential, commercial and light industry.
- BS EN 61000-6-3:2001+A11:2004. electro-magnetic compatibility. Generic standard. Residential, commercial and light industry.
- BS 7273-4:2007 Category B. Code of practice for the operation of fire protection measures. Activation of release mechanism for doors.
- USA patent number: 5525963
- European patent number: 0635092

### Dorgard X 1328-A02 (radio fire door retainer)

#### Dorgard TX (transmitter) 1328-A02/ TX

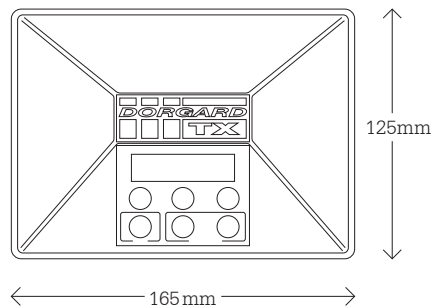

#### Dimensions and weight

- Height: 125 mm
- Width: 165 mm
- Depth: 55 mm
- Packed kit weight: 670 g
- Product only (including batteries): 380 g

#### Material and operating specifications

- Casing: ABS
- Power: 4 x 1.5v C size alkaline batteries (do not use rechargeable batteries)
- Expected battery life: 12 months

#### Dorgard RX (receiver) 1328-A02/ RX

#### Dimensions and weight

- As per Dorgard 1328-A01

**Tel: 01536 790999**

**Fax: 01536 790710**

**info@doorguard.org**

**www.doorguard.org**

**Online Sales**